

1-Line, Bi-directional, Transient Voltage Suppressor

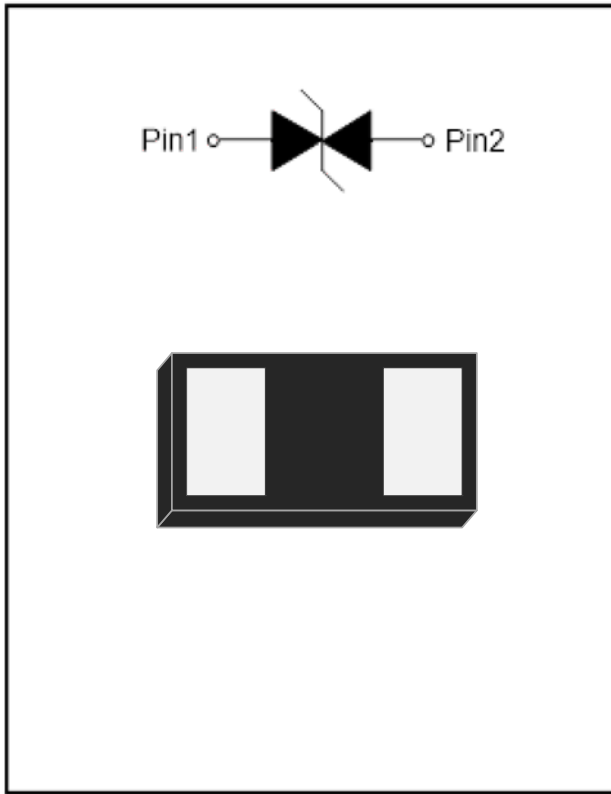

Features

- High surge current capability
- Low leakage current
- Low clamping voltage
- Low peak pulse current

Applications

- Protection of sensitive electronic components
- Protection of data lines
- Protection of power lines

Mechanical Data

- Pin 1+ Pin 2+
- Package type: 7H

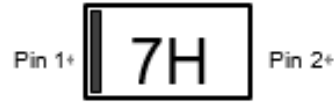

Definitions of electrical characteristics

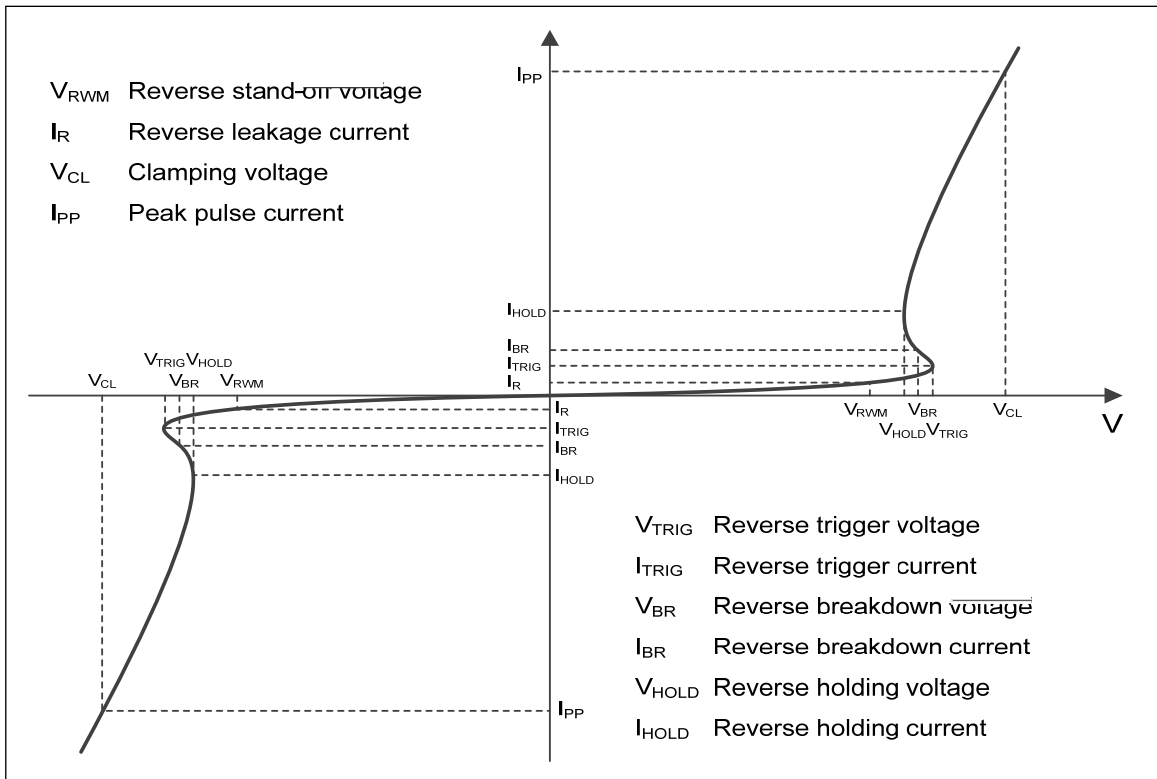



Characteristics (Typical)

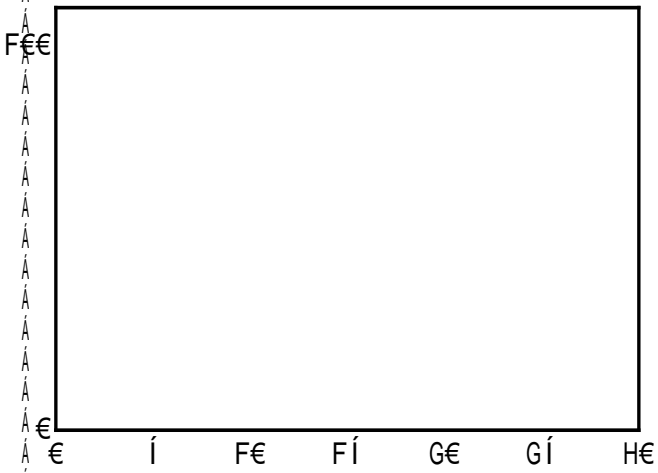

ÁHÁDÁ T Á



ESD7V0LBA

Fig.7 ESD clamping

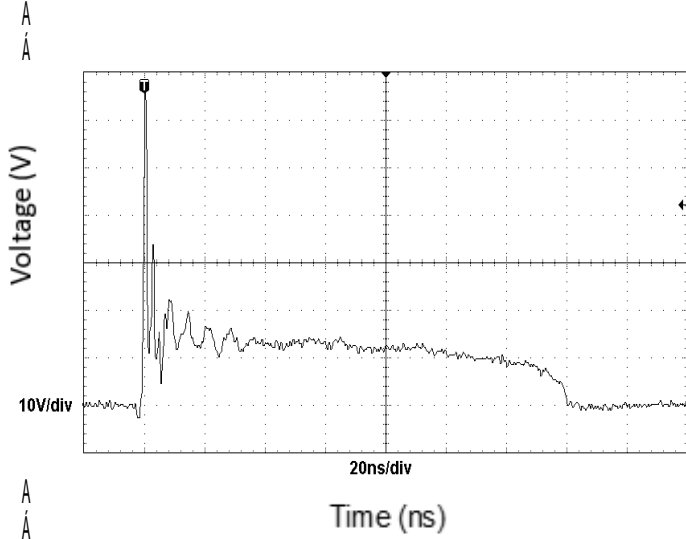

(+8kV contact discharge per IEC61000-4-2)

Fig.8 ESD clamping t

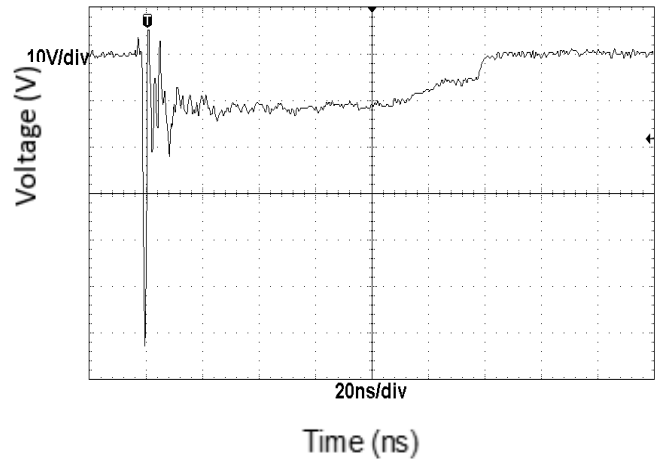

(-8kV contact discharge per IEC61000-4-2)

Fig 9 TLP Measurement

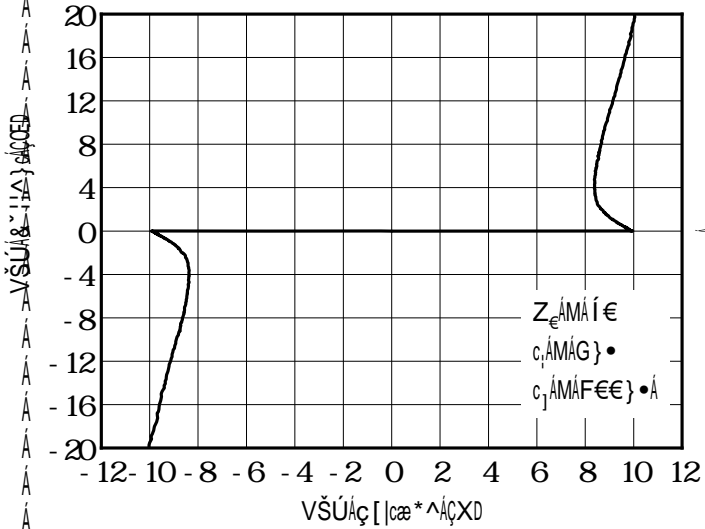



ESD7V0LBA

Outline Dimensions

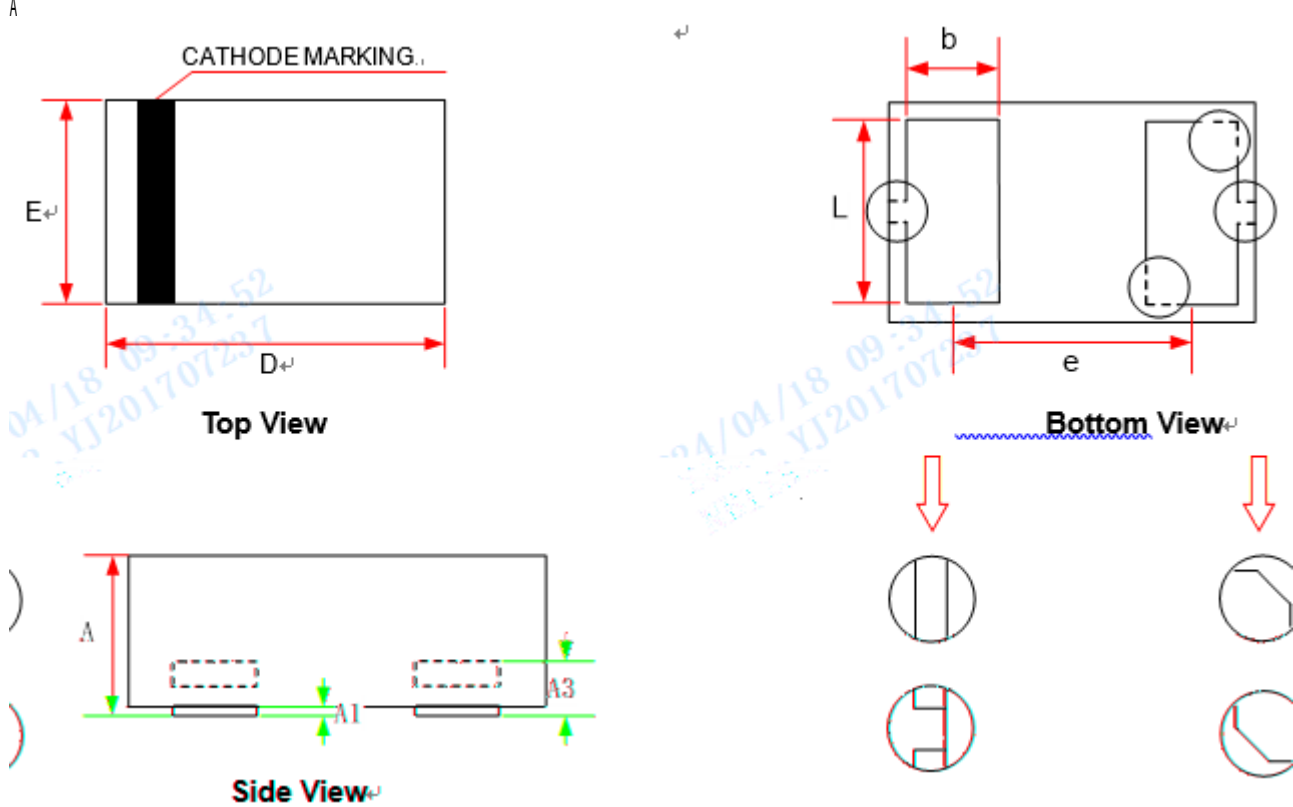

| | | | |
|----|------------|-------|-------|
| | | | |
| A | 0.340 | 0.450 | 0.530 |
| A1 | 0.000 | 0.020 | 0.050 |
| A3 | 0.125 Ref. | | |
| D | 0.950 | 1.000 | 1.080 |
| E | 0.550 | 0.600 | 0.680 |
| b | 0.200 | 0.250 | 0.300 |
| L | 0.450 | 0.500 | 0.550 |
| e | 0.650 BSC | | |

Recommended PCB Layout

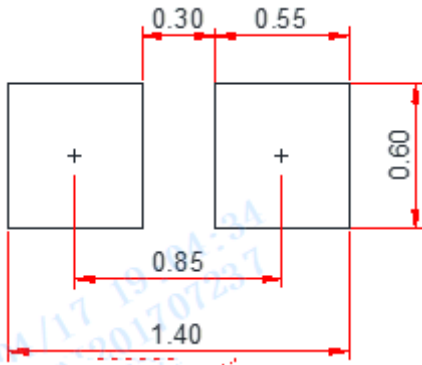

Unit:mm

ρ [c^kA
 $V @ \dot{a} \cdot \dot{A} \cdot \dot{\wedge} \& [\{ \{ \wedge \} \dot{a} \wedge \dot{a} \dot{A} | \dot{\otimes} \} \dot{a} \dot{A}] \dot{\otimes} \dot{c} \dot{c} \dot{\wedge} \dot{!} \} \dot{A} \dot{a} \dot{A} - [\dot{!} \dot{A} \dot{\wedge} - \dot{\wedge} \dot{!} \dot{\wedge}] \dot{\wedge} \dot{A} \dot{!} \dot{!} [\dot{\cdot} \dot{\wedge} \dot{A} [\dot{\cdot}] \dot{\wedge} \dot{A}] \dot{\wedge} \dot{A}$
 $\dot{U} | \dot{\wedge} \dot{\otimes} \cdot \dot{\wedge} \dot{A} \dot{\wedge} [\dot{\cdot}] \cdot \dot{\sim} | \dot{c} \dot{\wedge} [\dot{\sim} \dot{!} \dot{A} \{ \dot{\otimes} \} \dot{\sim} \dot{\otimes} \dot{c} \dot{\sim} \dot{!} \dot{a} \} \cdot \dot{A} \cdot \dot{!} [\dot{\sim}] \dot{A} \dot{c} [\dot{A} \dot{\wedge}] \cdot \dot{\sim} \dot{!} \dot{\wedge} \dot{\wedge} [\dot{\sim} \dot{!} \dot{A} \dot{U} \dot{O} \dot{O} \dot{A}$
 $\dot{a} \dot{\wedge} \dot{a} \dot{\cdot} \dot{A} \dot{\sim} \dot{a} \dot{\wedge} \dot{!} \dot{a} \dot{\cdot} \dot{\otimes} \dot{!} \dot{\wedge} \dot{A} \{ \dot{\wedge}$

Á Í Á Ð Á Ñ Á

