



# YJD27G10A

---

## N-Channel Enhancement Mode Field Effect Transistor

### Product Summary

$V_{DS}$	100V
$I_D$	27A
$R_{DS(ON)}$ ( at $V_{GS}=10V$ )	29m
$R_{DS(ON)}$ ( at $V_{GS}=4.5V$ )	47m
100% EAS Tested	
100% $V_{DS}$ Tested	



**YJD27G10A**



# YJD27G10A

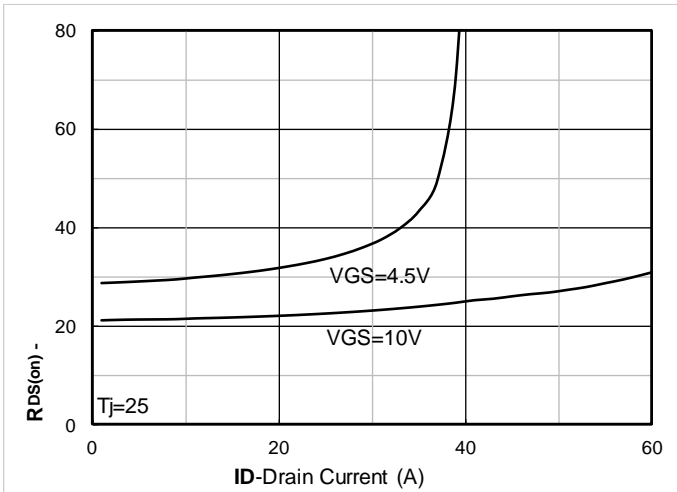

Figure 7. RDS(on) VS Drain Current

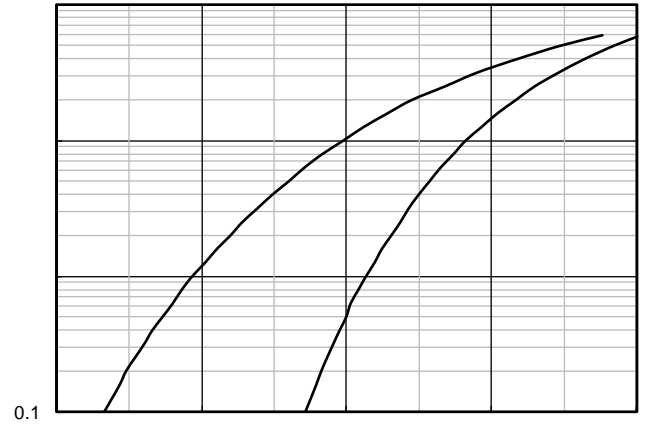

Figure 8. Forward characteristics of reverse diode

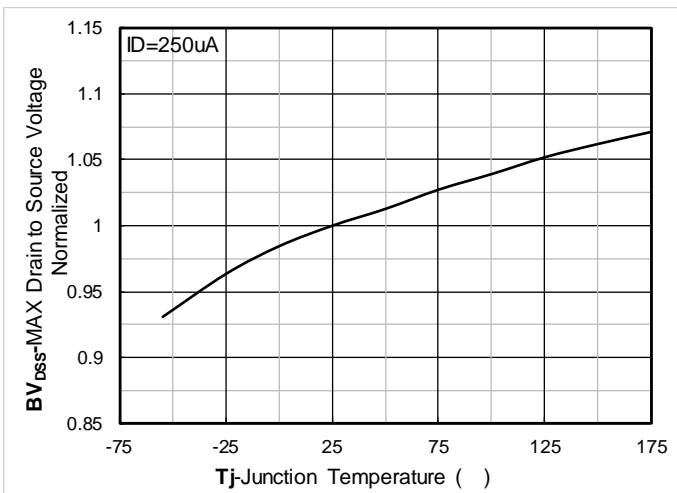

Figure 9. Normalized breakdown voltage

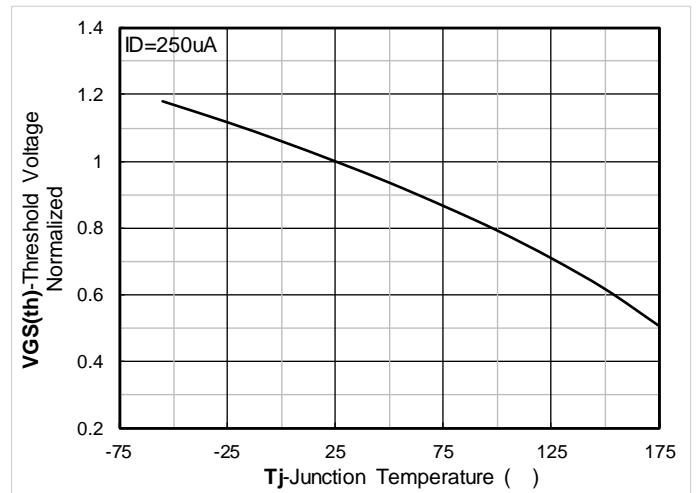

Figure 10. Normalized threshold voltage





# YJD27G10A



Figure B. Gate Charge Test Circuit & Waveform

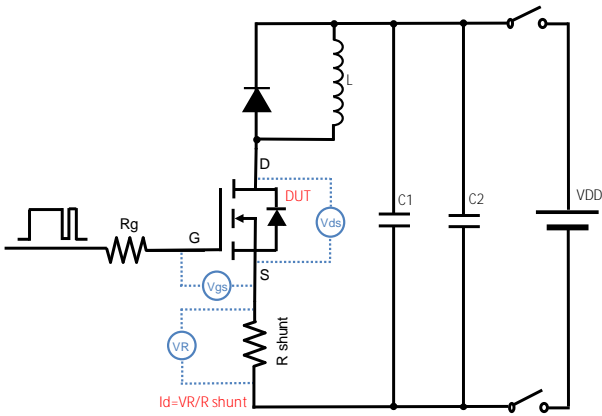

Figure C. Resistive Switching Test Circuit & Waveform

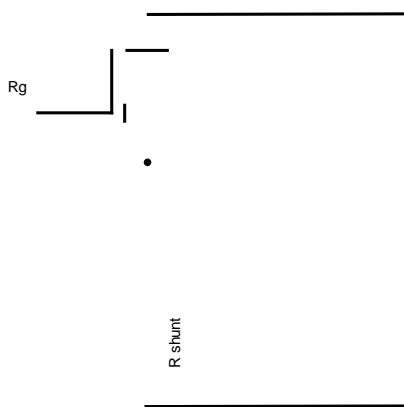
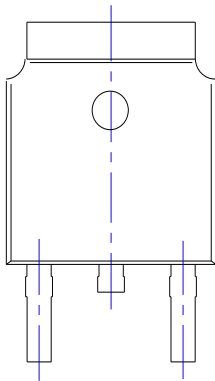

Figure D. Diode Recovery Test Circuit & Waveform



# YJD27G10A

## TO-252-B Package information



TOP VIEW



SIDE VIEW

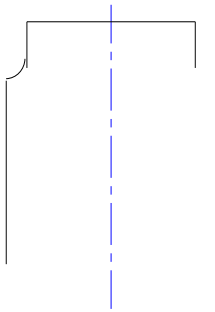

BOTTOM VIEW

SUGGESTED SOLDER PAD LAYOUT

SYMBOL	DIMENSIONS				
	INCHES				
	MIN.	NOM.			
A1	0.000				
A2	0.087	0.091			
A3	0.035	0.039			
b	0.026	0.030			
c	0.018	0.020			
D	0.256	0.260			
D1					
D2	0.181	0.189			
E	0.390	0.398			
E1	0.236	0.240			

**NOTE:**

- 1.PACKAGE BODY SIZES EXCLUDE MOLD FLASH AND GATE BURRS.
- 2.TOLERANCE 0.1mm UNLESS OTHERWISE SPECIFIED.
- 3.THE PAD LAYOUT IS FOR REFERENCE PURPOSES ONLY.

**YJD27G10A**