



## N-Channel Enhancement Mode Field Effect Transistor

### Product Summary

$V_{DS}$	80V
$I_D$	100A
$R_{DS(ON)}$ ( at $V_{GS}=10V$ )	4.5mohm
100% EAS Tested	
100% $V_{DS}$ Tested	

### General Description

Split gate trench MOSFET technology  
 Excellent package for heat dissipation  
 High density cell design for low  $R_{DS(ON)}$   
 Moisture Sensitivity Level 1  
 Epoxy Meets UL 94 V-0 Flammability Rating  
 Halogen Free

### Applications

Battery protection  
 Load switch  
 Uninterruptible power supply

### Absolute Maximum Ratings ( $T_A=25$ unless otherwise noted)

Parameter		Symbol	Limit	Unit
Drain-source Voltage		$V_{DS}$	80	V
Gate-source Voltage		$V_{GS}$	$\pm 20$	V
Drain Current	$T_C=25$	$I_D$	100	A
	$T_C=100$		63	
Pulsed Drain Current <sup>A</sup>		$I_{DM}$	400	A
Avalanche energy <sup>B</sup>		EAS	600	mJ
Total Power Dissipation <sup>C</sup>	$T_C=25$	$P_D$	152	W
	$T_C=100$		61	
Junction and Storage Temperature Range		$T_J, T_{STG}$	-55	



# YJG100G08A

---

RECOMMEND  
YJG90G08HJR  
FOR NEW DESIGN

# YJG100G08A

---

RECOMMEND  
YJG90G08HJR  
FOR NEW DESIGN

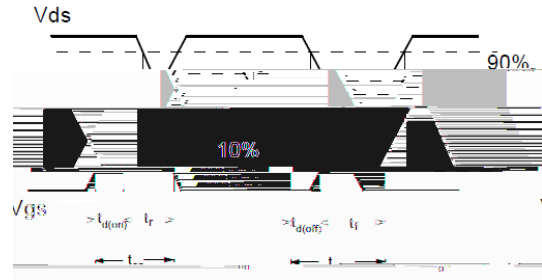
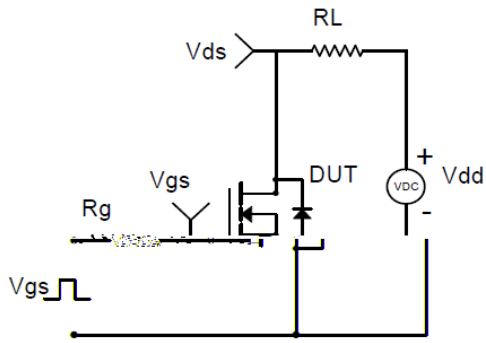

**Resistive Switching Test Circuit & Waveforms**

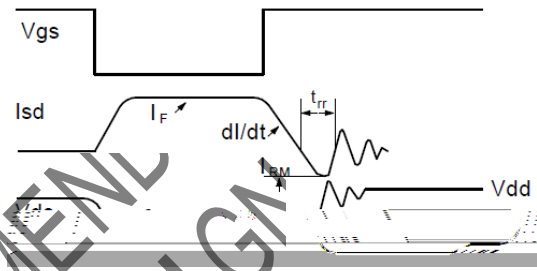
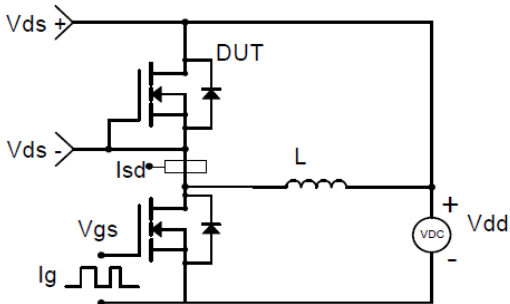

**Diode Recovery Test Circuit & Waveforms**

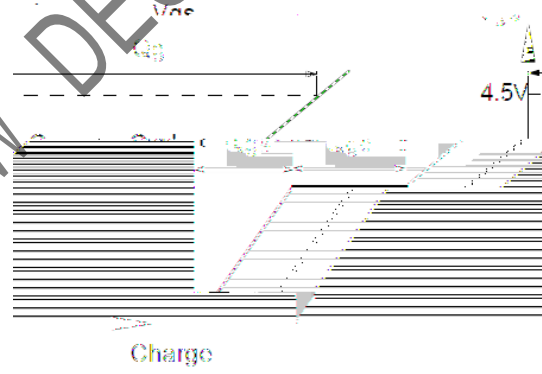
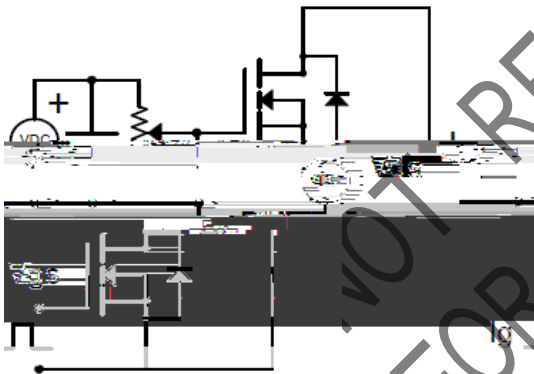

**Gate Charge Test Circuit & Waveform**

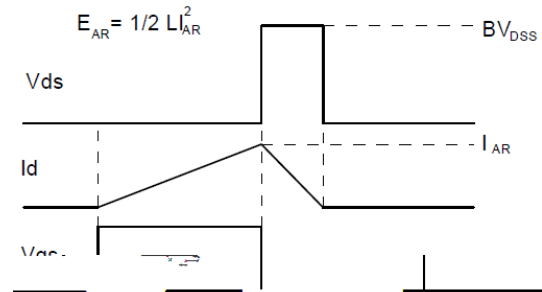
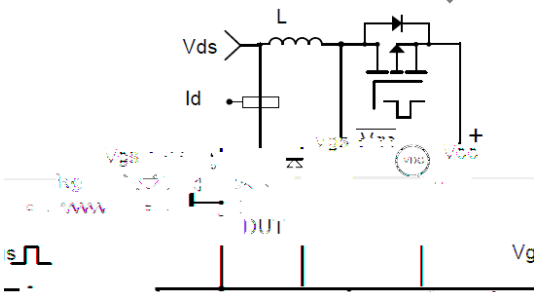

**Unclamped Inductive Switching (UIS) Test Circuit & Waveforms**





## Disclaimer

The information presented in this document is for reference only. Yangzhou Yangjie Electronic Technology Co., Ltd. reserves the right to make changes without notice for the specification of the products displayed herein to improve reliability, function or design or otherwise.

The product listed herein is designed to be used with ordinary electronic equipment or devices, and not designed to be used with equipment or devices which require high level of reliability and the malfunction of which would directly endanger human life (such as medical instruments, transportation equipment, aerospace machinery, nuclear-reactor controllers, fuel controllers and other safety devices), Yangjie or anyone on its behalf, assumes no responsibility or liability for any damages resulting from such improper use of sale.

This publication supersedes & replaces all information p