

N-Channel Enhancement Mode Field Effect Transistor

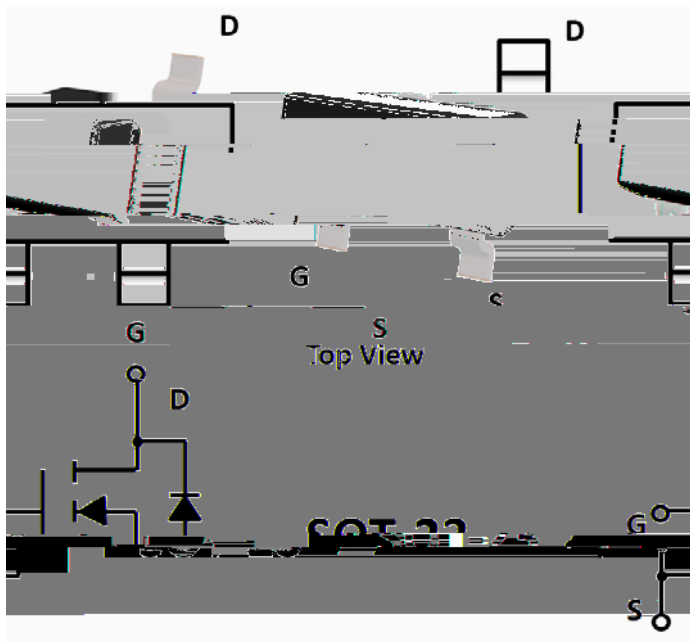

Product Summary

V_{DS}	20V
I_D	4.3A
$R_{DS(ON)}$ (at $V_{GS}= 4.5V$)	27mohm
$R_{DS(ON)}$ (at $V_{GS}= 2.5V$)	37mohm

General Description

Trench Power LV MOSFET technology
High Density Cell Design for Low $R_{DS(ON)}$
High Speed switching
Part no. with suffix "Q" means AEC-Q101 qualified

Applications

Battery protection
Load switch
Power management

Absolute Maximum Ratings ($T_A=25$ unless otherwise noted)

Parameter	Symbol	Limit	Unit
Drain-source Voltage	V_{DS}	20	V
Gate-source Voltage	V_{GS}	± 10	V
Drain Current	I_D	$T_A=25$	4.3
		$T_A=70$	3.4
Pulsed Drain Current ^A	I_{DM}	17.2	A
Total Power Dissipation @ $T_A=25$ Steady State	P_D	1	W
Thermal Resistance Junction-to-Ambient ^B	R_{JA}	125	/W
Junction and Storage Temperature Range	T_J, T_{STG}	-55 +150	

Ordering Information (Example)

PREFERRED P/N	PACKING CODE	Marking	MINIMUM PACKAGE(pcs)	INNER BOX QUANTITY(pcs)	OUTER CARTON QUANTITY(pcs)	DELIVERY MODE
YJL2302AQ	F2	.2302.	3000	30000	120000	7" reel



YJL2302AQ

Electrical Characteristics (T_J=25 unless otherwise noted)

Parameter	Symbol	Conditions	Min	Typ	Max	Units
-----------	--------	------------	-----	-----	-----	-------



Typical Performance Characteristics

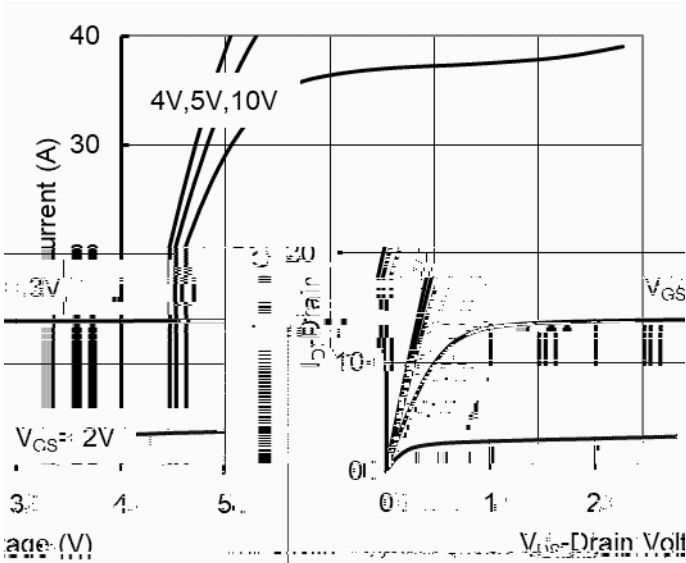

Figure1. Output Characteristics

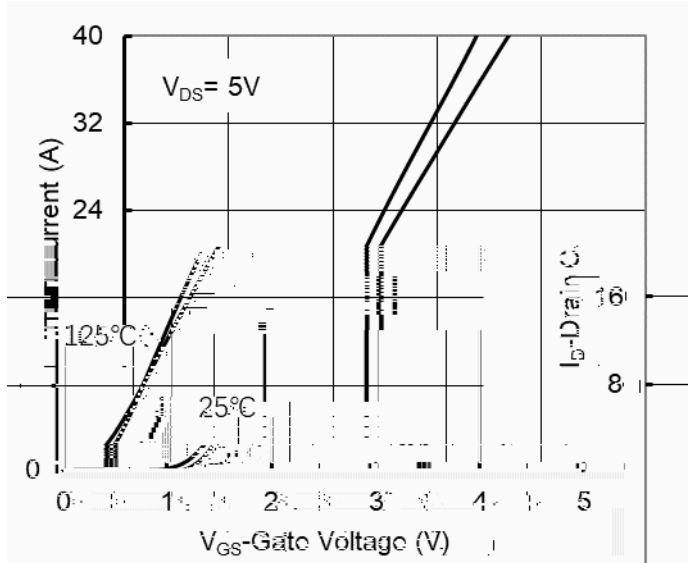

Figure2. Transfer Characteristics

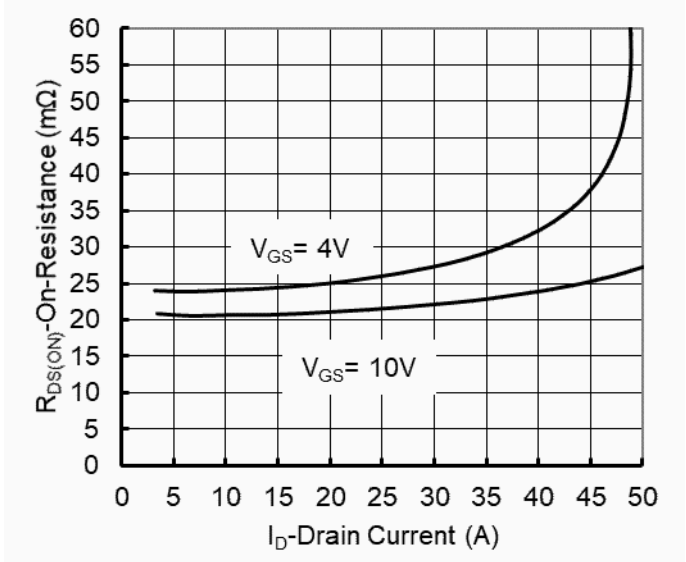

Figure 3: On-Resistance vs. Drain Current and Gate Voltage

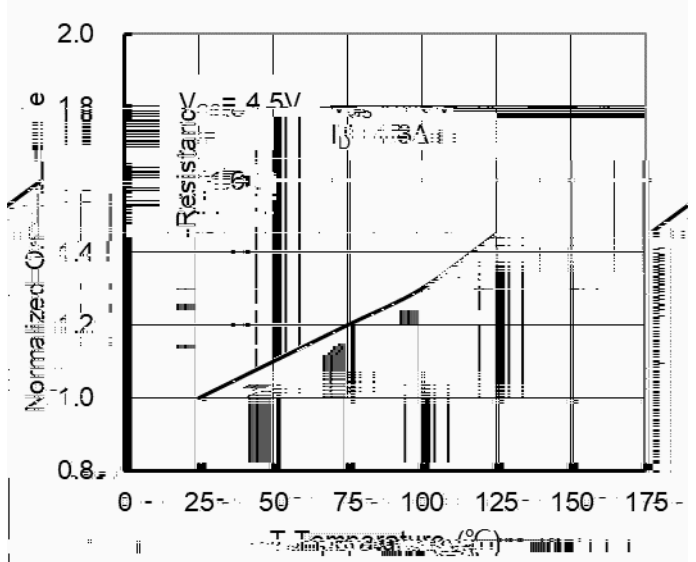

Figure 4: On-Resistance vs. Junction Temperature

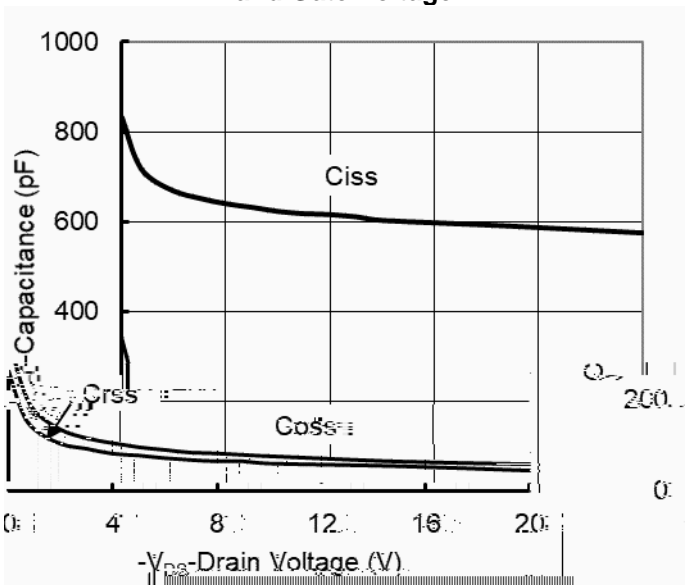

Figure5. Capacitance Characteristics

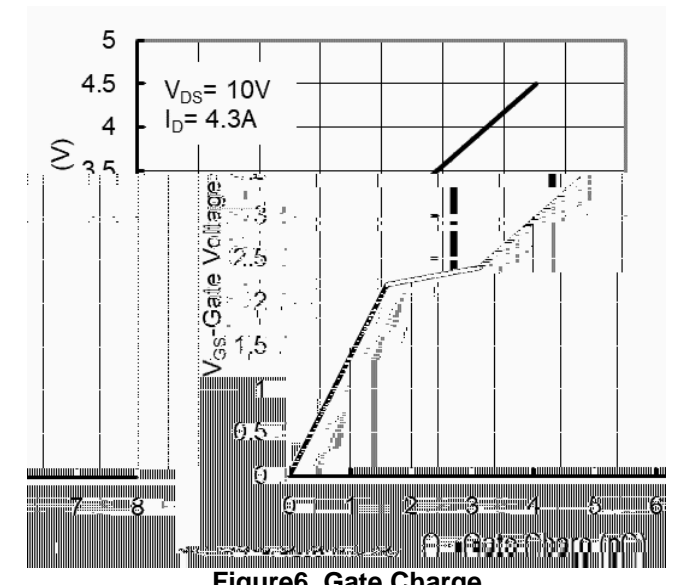

Figure6. Gate Charge

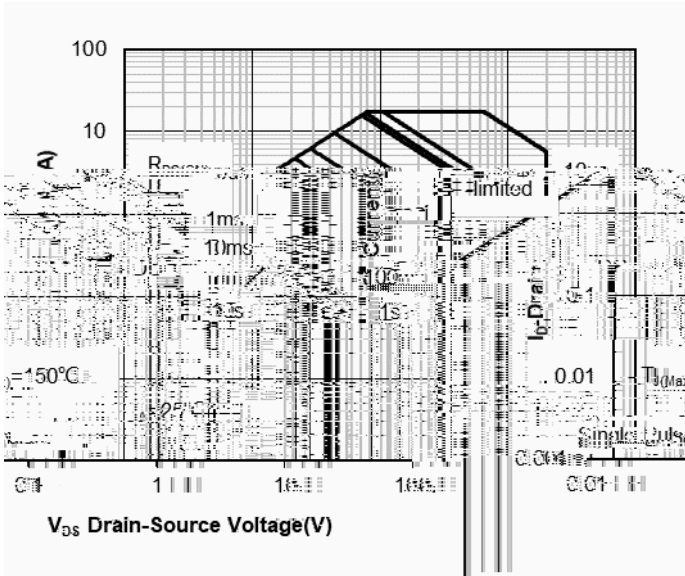
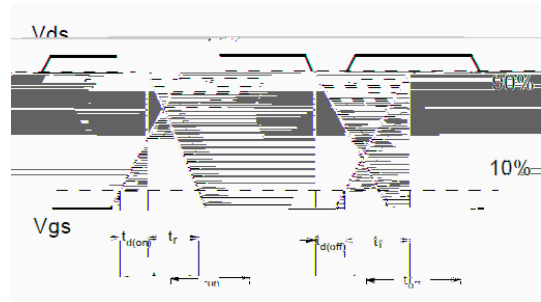
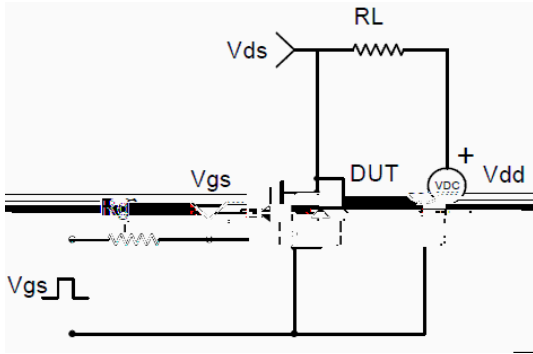
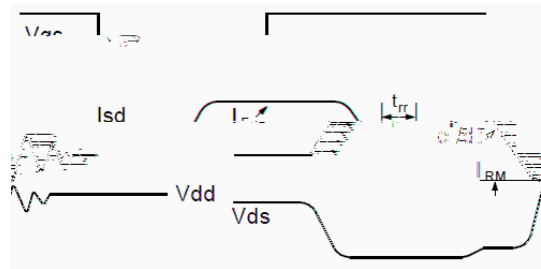
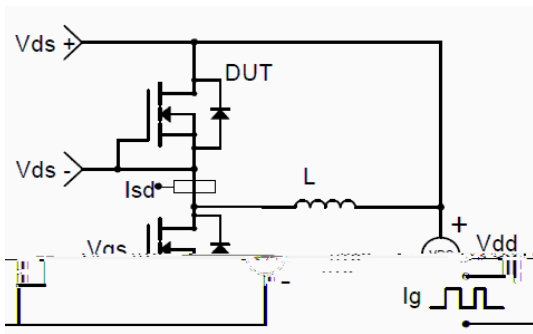

Fig. 10



Resistive Switching Test Circuit & Waveforms



Diode Recovery Test Circuit & Waveforms

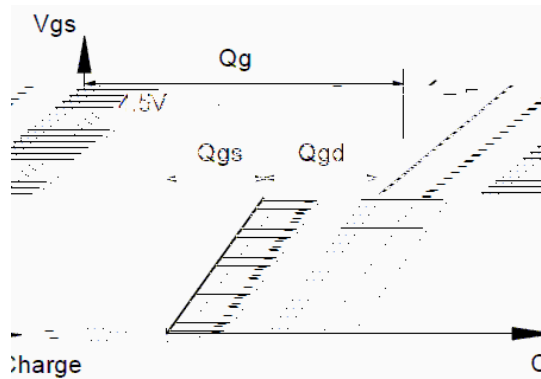
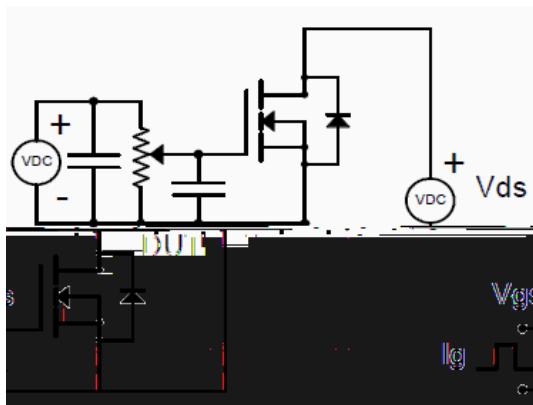

Gate Charge Test Circuit & Waveform

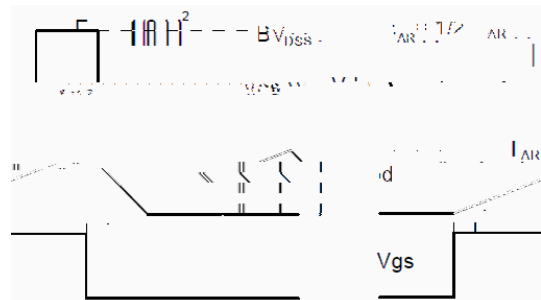
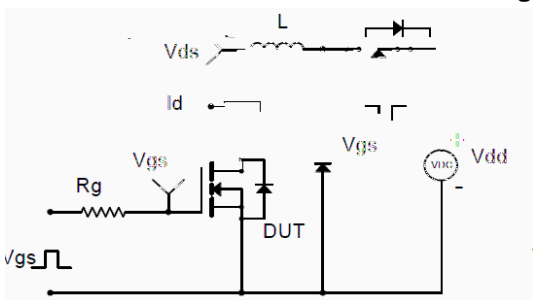

Unclamped Inductive Switching (UIS) Test Circuit & Waveforms



YJL2302AQ

SOT-23 Package information

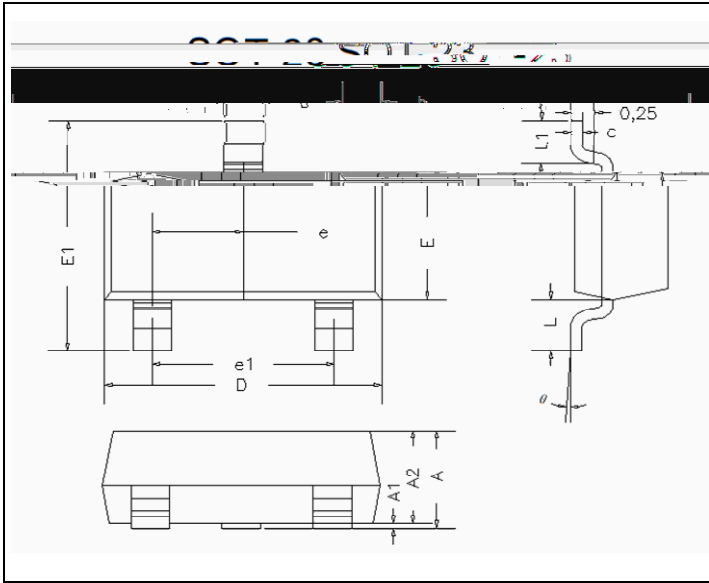

DIM	INCHES		MM		NOTE
	MIN	MAX	MIN	MAX	
A	0.035	0.045	0.90	1.15	
A1	0.000	0.004	0.00	0.10	
A2	0.035	0.041	0.90	1.05	
b	0.012	0.020	0.30	0.50	
c	0.004	0.008	0.10	0.20	
D	0.110	0.118	2.80	3.00	
E	0.047	0.055	1.20	1.40	
E1	0.089	0.100	2.25	2.55	
e	0.370TYP		0.95TYP		
e1	0.071	0.079	1.80	2.00	
L	0.220REF		0.55REF		
L1	0.012	0.020	0.30	0.50	
	0°	8°	0°	8°	

