



N-Channel Enhancement Mode Field Effect Transistor

Product Summary

V_{DS}	30V
I_D	0.4A
$R_{DS(ON)}$ (at $V_{GS}=10V$)	2.5
$R_{DS(ON)}$ (at $V_{GS}=4.5V$)	3
Gate-Source ESD Rating Up to 2KV (HBM)	

General Description

Excellent package for heat dissipation
High density cell design for low $R_{DS(ON)}$
Moisture Sensitivity Level 1
Epoxy Meets UL 94 V-0 Flammability Rating
Halogen Free

Applications

Power switching application
Uninterruptible power supply
DC-DC convertor

Absolute Maximum Ratings ($T_J=25$ unless otherwise noted)



Typical Electrical and Thermal Characteristics Diagrams

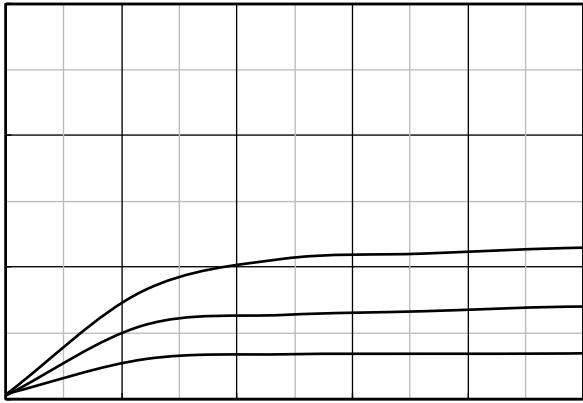

Figure 1. Output Characteristics

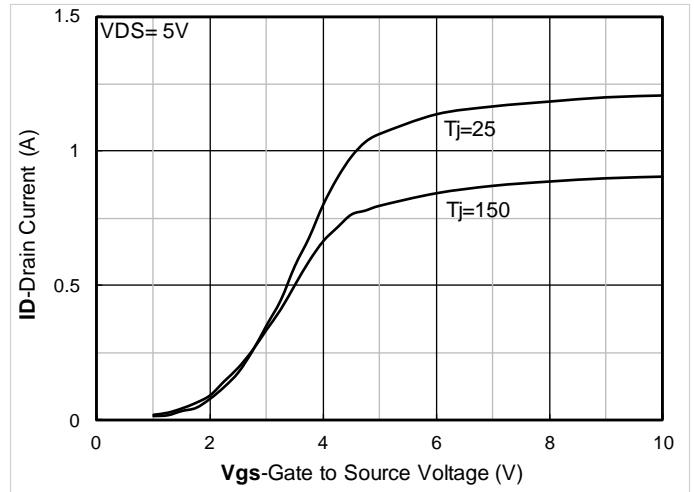

Figure 2. Transfer Characteristics

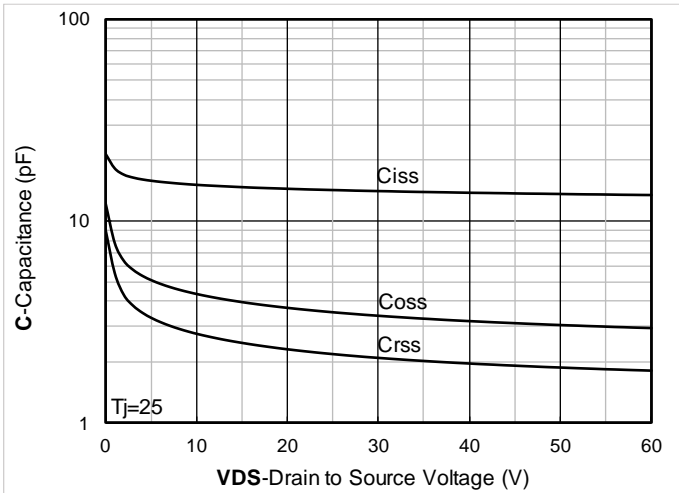

Figure 3. Capacitance Characteristics

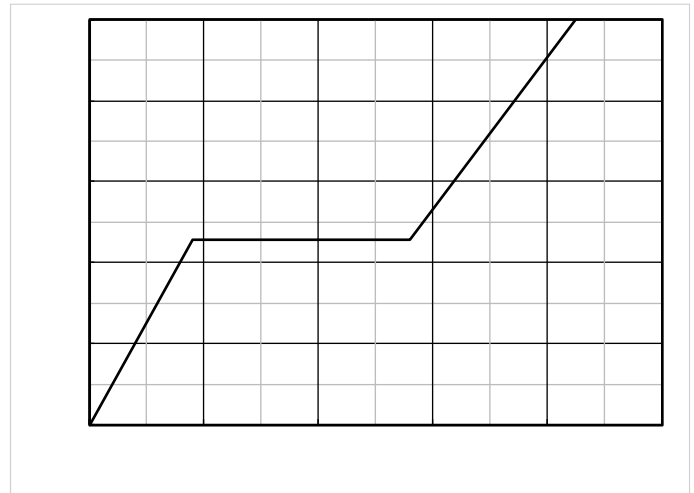

Figure 4. Gate Charge

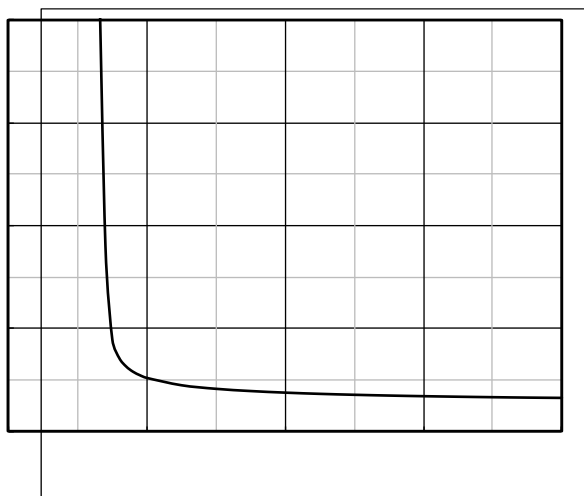

Figure 5. On-Resistance vs Gate to Source Voltage

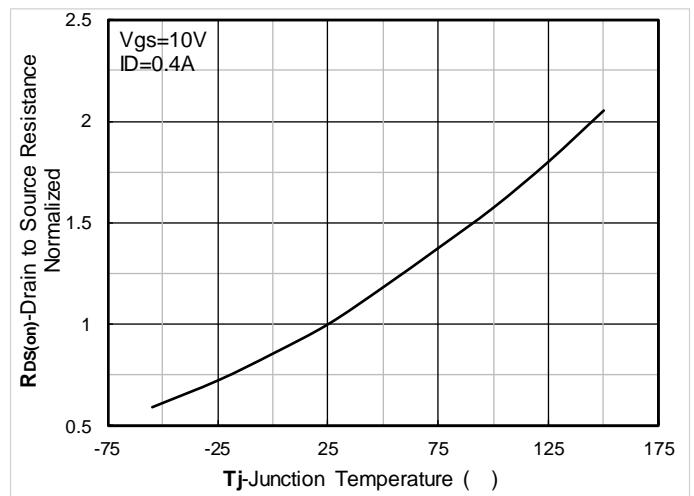

Figure 6. Normalized On-Resistance

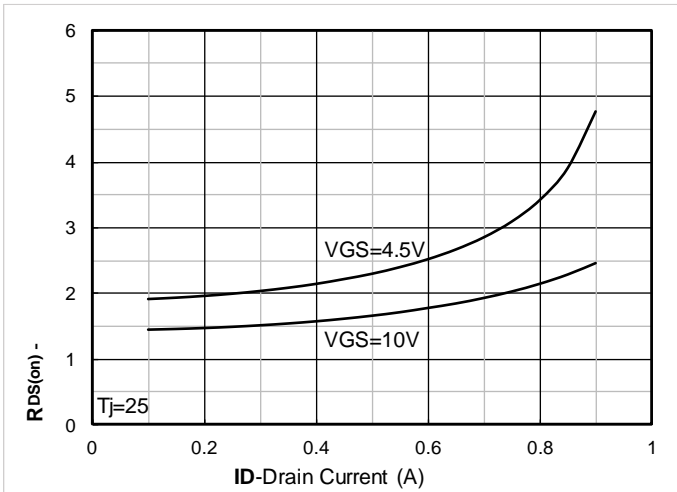

Figure 7. RDS(on) VS Drain Current

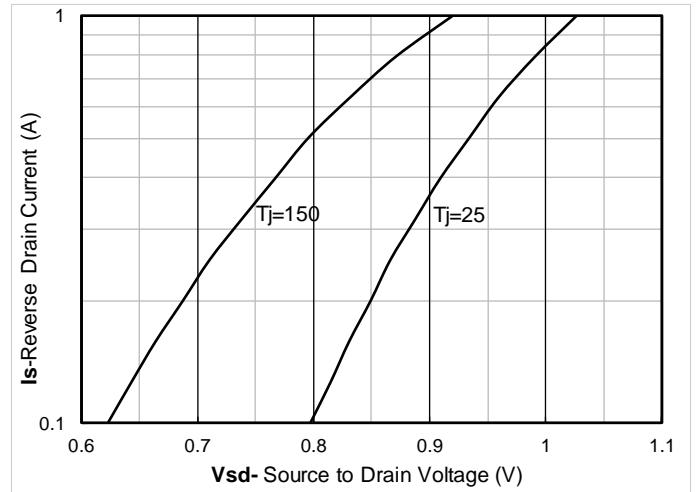

Figure 8. Forward characteristics of reverse diode

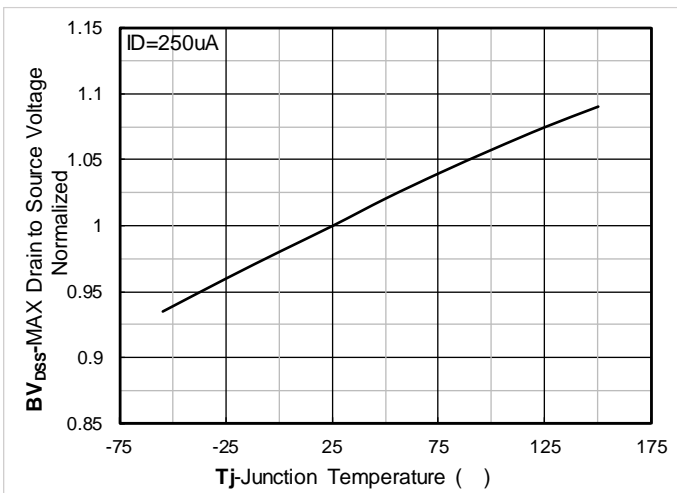

Figure 9. Normalized breakdown voltage

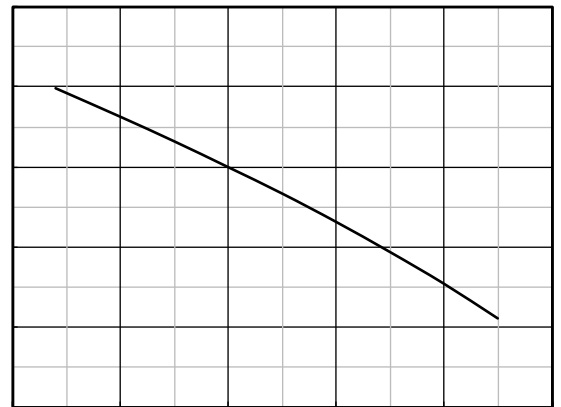

Figure 10. Normalized Threshold voltage

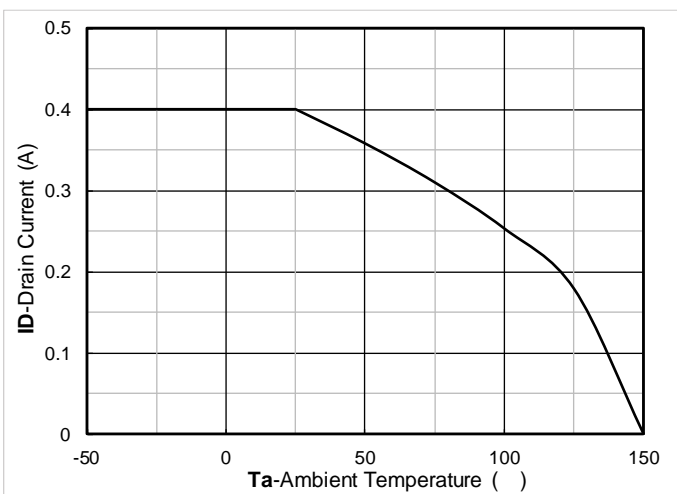

Figure 11. Current dissipation

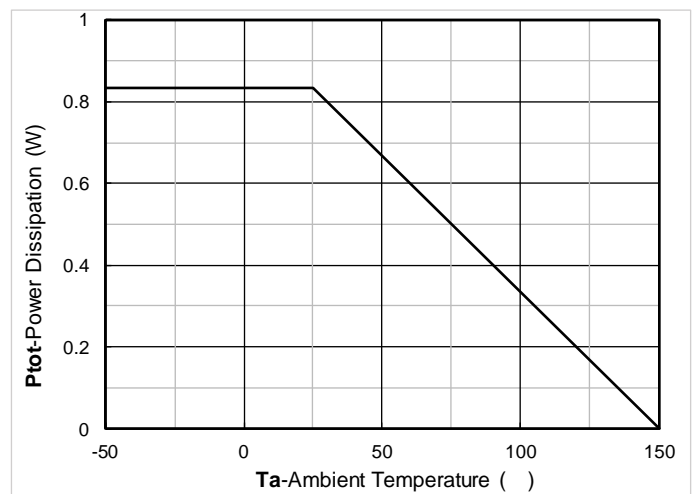

Figure 12. Power dissipation

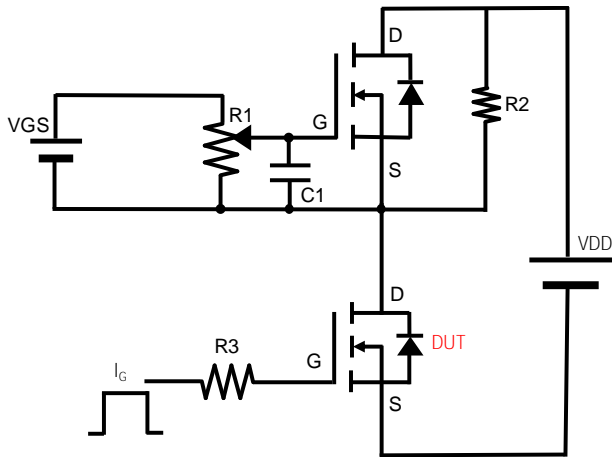

Figure B. Gate Charge Test Circuit & Waveform

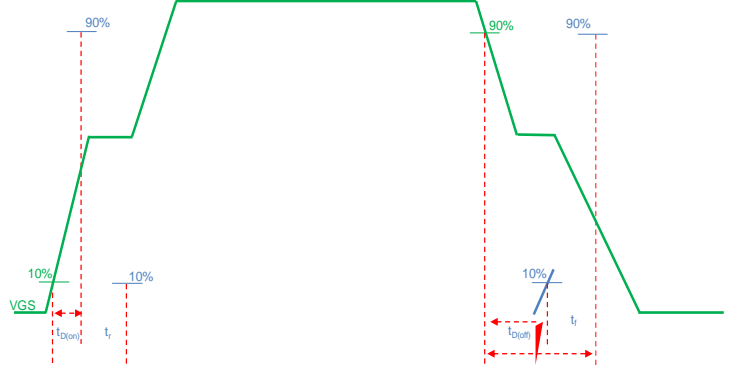
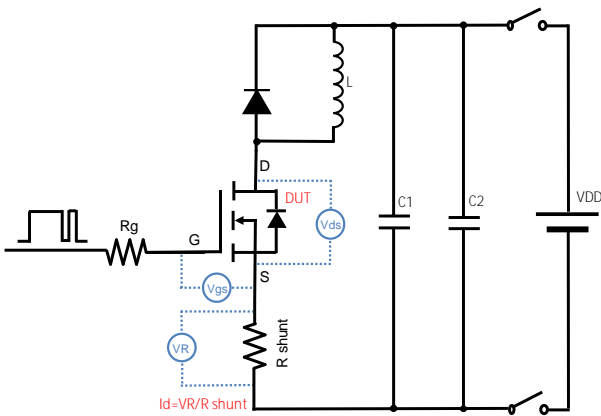

Figure C. Resistive Switching Test Circuit & Waveform

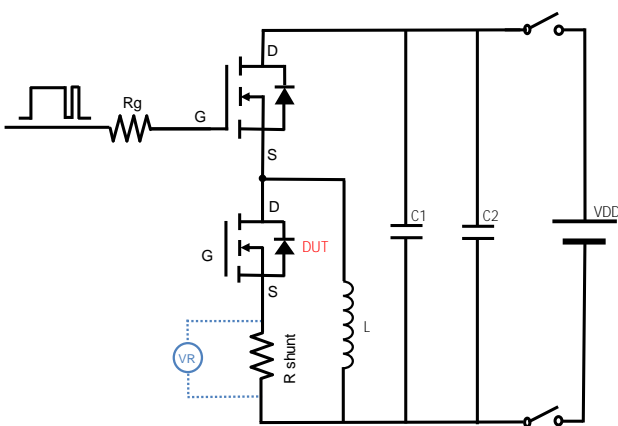
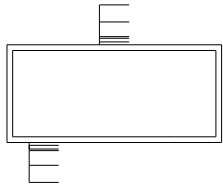

Figure D. Diode Recovery Test Circuit & Waveform



YJL3018KJ

SOT-23 Package information



TOP VIEW



SIDE VIEW

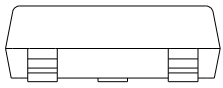

UNIT mm

SUGGESTED SOLDER PAD LAYOUT



YJL3018KJ

Disclaimer

The information presented in this document is for reference only. Yangzhou Yangjie Electronic Technology Co., Ltd. reserves the right to make changes without notice for the specification of the products displayed herein to improve reliability, function or design or otherwise.

The product listed herein is designed to be used with ordinary electronic equipment or devices, and not designed to be used with equipment or devices which require high level of reliability and the malfunction of which would directly endanger human life (such as medical instruments, transportation equipment, aerospace machinery, nuclear-reactor controllers, fuel controllers and other safety devices), Yangjie or anyone on its behalf, assumes no responsibility or liability for any damages resulting from such improper use of sale.

This publication supersedes & replaces all information previously supplied. For additional information, please visit our website <http://www.21yangjie.com>