



YJQ4D8G04H

N-Channel Enhancement Mode Field Effect Transistor

Product Summary

V_{DS}	40V
I_D	75A
$R_{DS(ON)}$ (at $V_{GS}=10V$)	4.8m
100% EAS Tested	
100% V_{DS} Tested	

General Description

Excellent package for heat dissipation
High density cell design for low $R_{DS(ON)}$



YJQ4D8G04H

Electrical Characteristics ($T_J=25$ unless otherwise noted)

Parameter	Symbol	Conditions	Min	Typ	Max	Units
Static Parameter						
Drain-Source Breakdown Voltage	BV_{DSS}	$V_{GS}=0V, I_D$	40	-	-	V
		$V_{GS}=0V, I_D=1mA$	40	-	-	V
Zero Gate Voltage Drain Current	I_{DSS}	$V_{DS}=40V, V_{GS}=0V$	-	-	1	
		$V_{DS}=40V, V_{GS}=0V, T_J=125$	-	-	100	

Gate-Body Leakage Current



Typical Electrical and Thermal Characteristics Diagrams

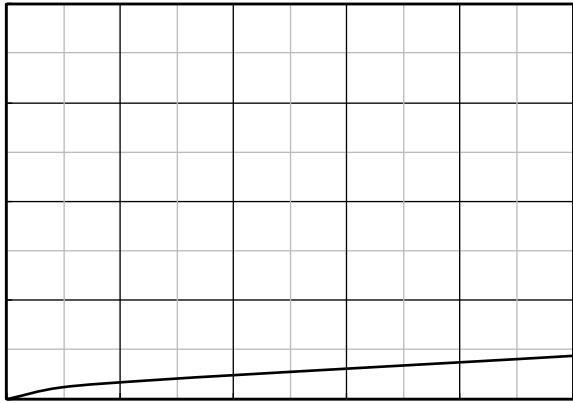

Figure 1. Output Characteristics

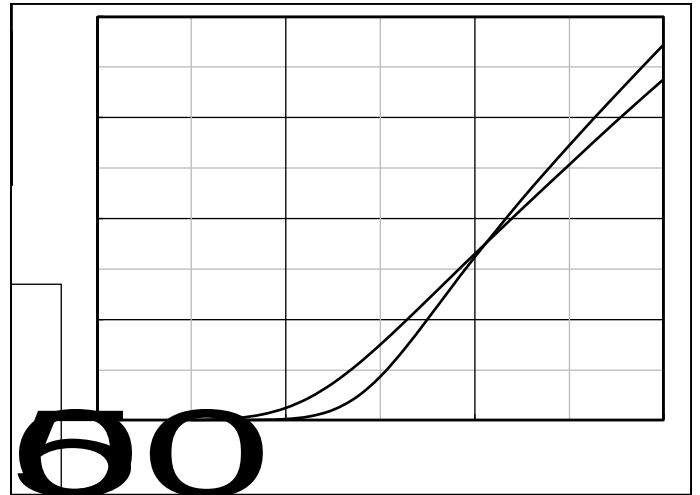

Figure 2. Transfer Characteristics

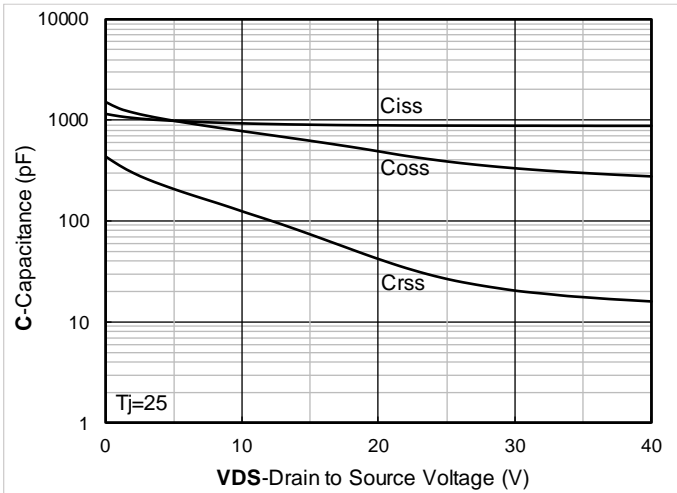

Figure 3. Capacitance Characteristics

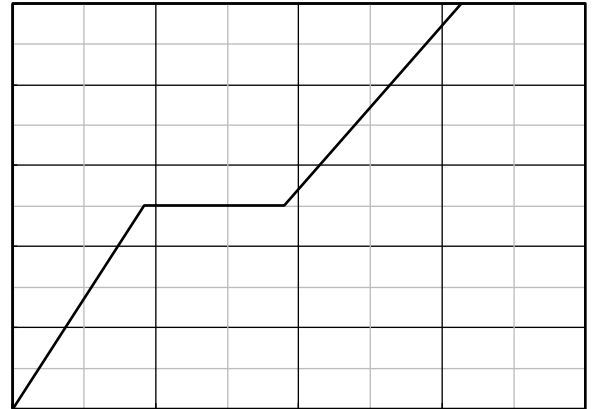

Figure 4. Gate Charge

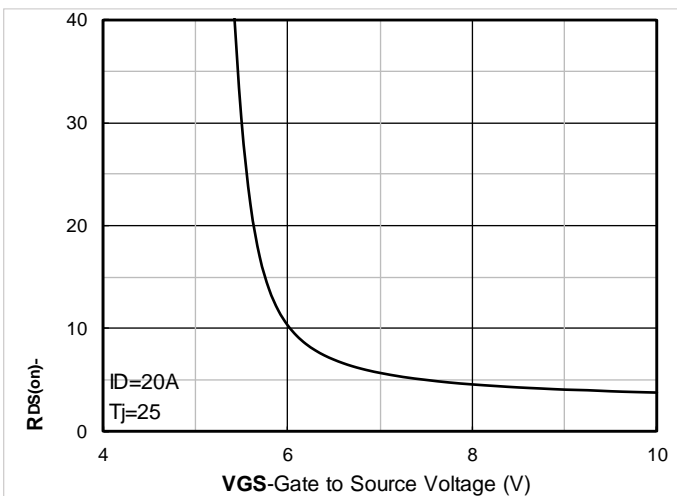

Figure 5. On-Resistance vs Gate to Source Voltage

Figure 6. Normalized On-Resistance



YJQ4D8G04H

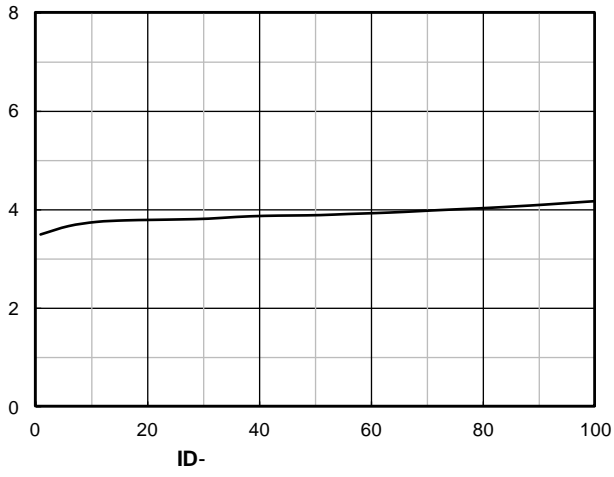
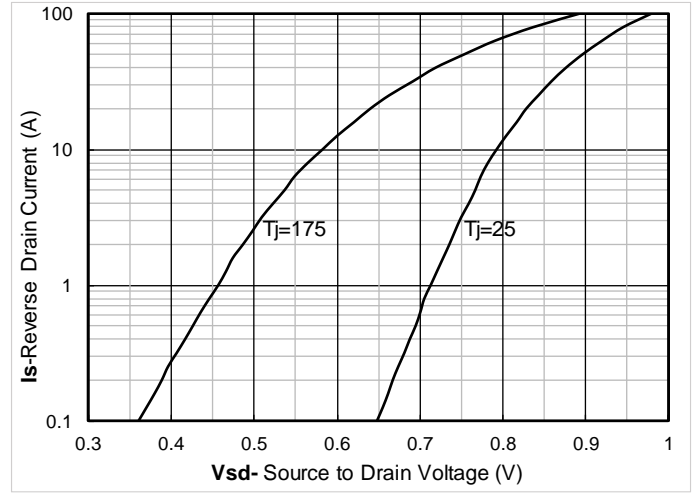

Figure 7. $R_{DS(on)}$





YJQ4D8G04H

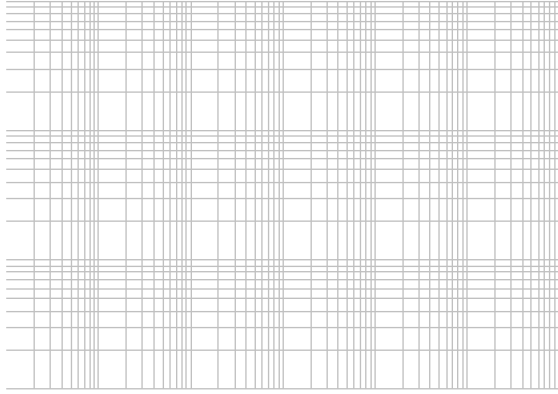

Figure 13. Maximum Transient Thermal Impedance

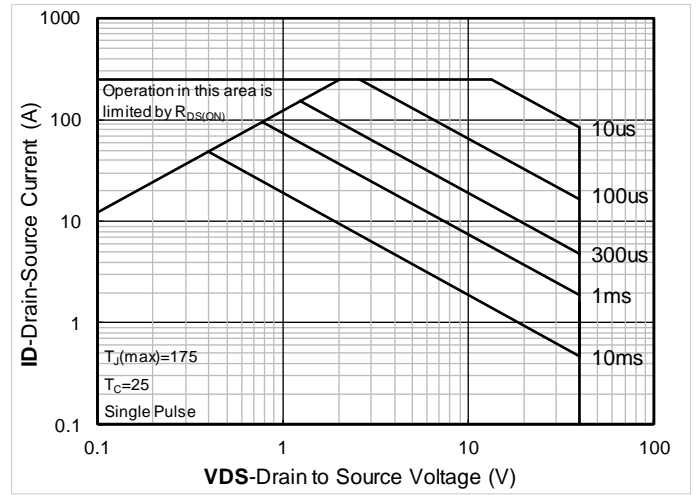

Figure 14. Safe Operation Area

Test Circuits & Waveforms



Figure A. Unclamped Inductive Switching (UIS) Test Circuit & Waveform



YJQ4D8G04H

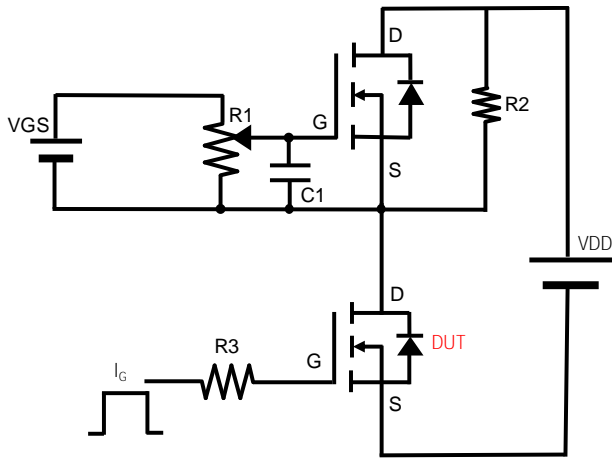

Figure B. Gate Charge Test Circuit & Waveform

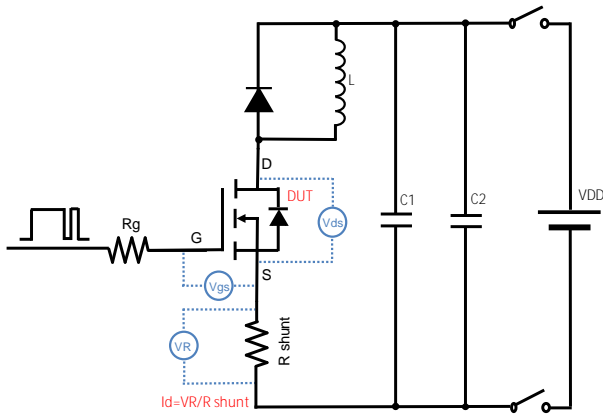

Figure C. Resistive Switching Test Circuit & Waveform

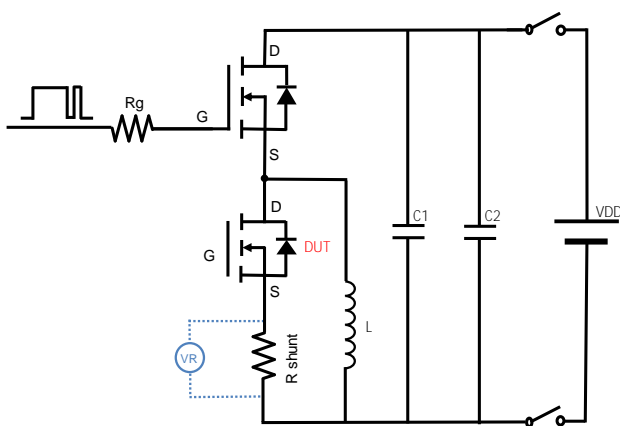
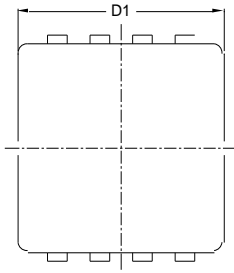

Figure D. Diode Recovery Test Circuit & Waveform



YJQ4D8G04H

PDFN3333-8L-B-0.75MM Package information



TOP VIEW

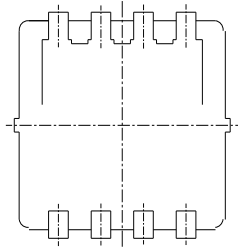

BOTTOM VIEW

SIDE VIEW

NOTE:

- 1.PACKAGE BODY SIZES EXCLUDE MOLD FLASH AND GATE BURRS.
- 2.TOLERANCE 0.1mm UNLESS OTHERWISE SPECIFIED.
- 3.THE PAD LAYOUT IS FOR REFERENCE PURPOSES ONLY.

UNIT mm

SUGGESTED SOLDER PAD LAYOUT



YJQ4D8G04H

Disclaimer

The information presented in this document is for reference only. Yangzhou Yangjie Electronic Technology Co., Ltd. reserves the right to make changes without notice for the specification of the products displayed herein to improve reliability, function or design or otherwise.

The product listed herein is designed to be used with ordinary electronic equipment or devices, and not designed to be used with equipment or devices which require high level of reliability and the malfunction of which would directly endanger human life (such as medical instruments, transportation equipment, aerospace machinery, nuclear-reactor controllers, fuel controllers and other safety devices), Yangjie or anyone on its behalf, assumes no responsibility or liability for any damages resulting from such improper use of sale.

This publication supersedes & replaces all information previously supplied. For additional information, please visit our website <http://www.21yangjie.com>