

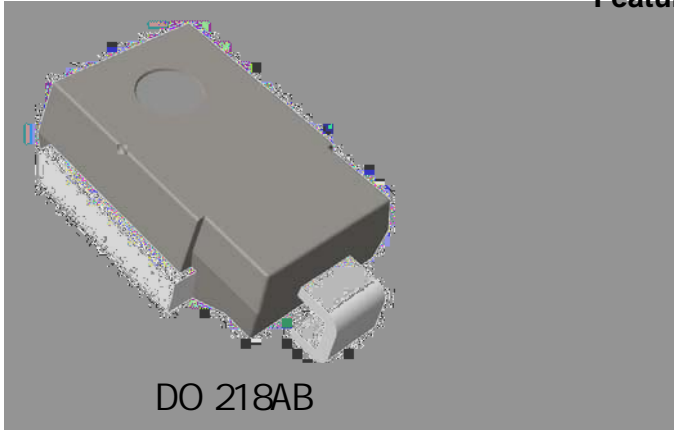

Surface Mount Transient Voltage Suppressors

Features



Uni-directional



Bi-directional

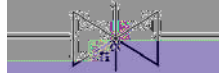

Mechanical Data

Package
Molding compound:
Polarity:

Maximum Ratings

PARAMETER	SYMBOL	UNIT	Value

Note:



SM5S10AQ THRU SM5S43CAQ

Characteristics

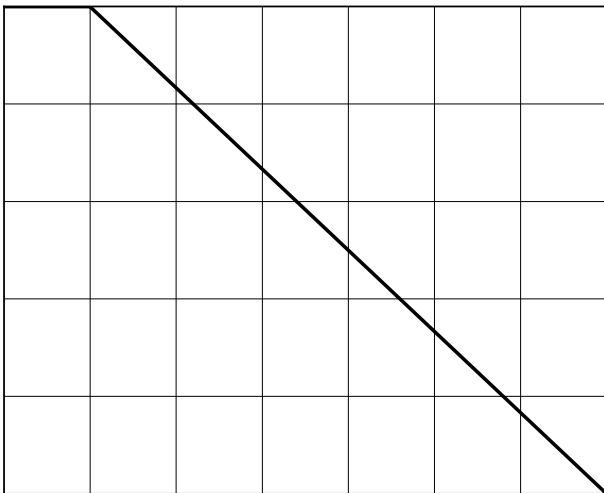
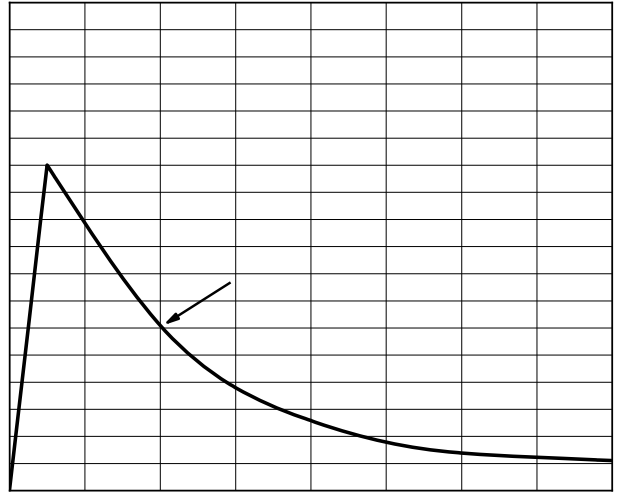
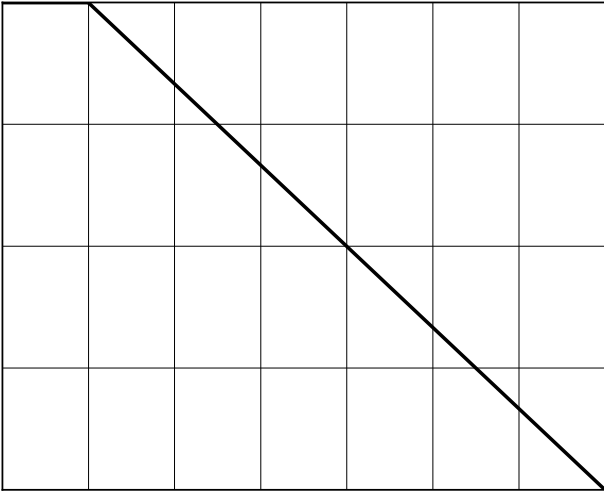



SM5S10AQ THRU SM5S43CAQ

Ordering Information

PREFERED P/N	PACKING CODE	UNIT WEIGHT(g)	MINIMUM
--------------	-----------------	----------------	---------
